

After the starter has been installed, there should be 1/16" (0.062) minimum between the engine side of the ring gear and the front edge of the teeth on the starter pinion gear. Check this distance with the ring gear in at least three different positions. If the distance is too little, shims can be installed inside the starter, which will pull the pinion into the starter an additional 1/16" (0.062). This will result in additional clearance between the pinion and the ring gear.

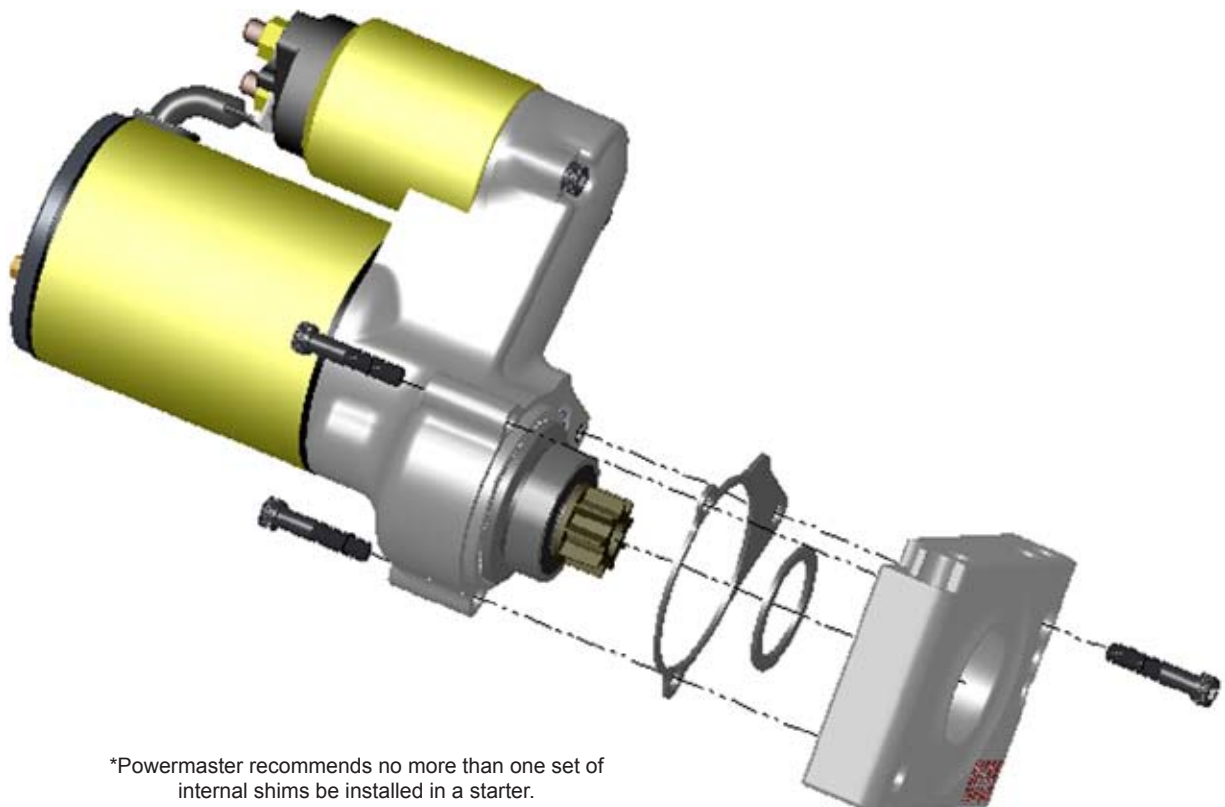

1. Remove the three socket head bolts that hold the billet mounting block to the starter-assembly. One bolt is located on the pinion gear side of the block, and two are located near the starter side of the block.
2. Remove the mounting block from the starter by pulling on both ends of the block, while pressing the pinion gear with both thumbs. Observe where all internal parts are located upon disassembly.
3. Place the round spacer shim in the bearing bore of the mounting block. This shim should be located between the pinion side bearing and the billet block and be visible behind the pinion gear after the starter has been reassembled.
5. The large triangular/pear shaped shim should be installed between the billet mounting block and the starter body.
6. Reinstall the three starter-assembly bolts and tighten.



*Powermaster recommends no more than one set of internal shims be installed in a starter.